

## Applications

### PHT-404

The P Audio PHT-404 is an integrated high frequency horn and compression driver. The design yields very extended high frequency response and controlled directivity in a rectangular geometry. The rated coverage pattern is 100 degree horizontal by 60 degree vertical. This rated coverage pattern is ideal for short throw applications such as foreground and background music system designs found in restaurants, pubs, and retail environments. The PHT-404 has a rated bandwidth of 3kHz to beyond 16kHz. This frequency response range makes the system excellent for wide coverage upper midrange and high frequency operation. The PHT-404 is ideally mated with a 10 inch, or 8 inch low frequency loudspeaker in a two way design.

The PHT-404 features a 1 inch diameter (25.4mm) phenolic based diaphragm assembly. The small format (1 inch) diaphragm is ideal for maintaining piston range performance in the upper frequency range. The wide horizontal mouth (10.6 inches, 269mm) maintains very good horizontal coverage control. The high sensitivity of 105 dB (1 watt at 1 meter) allows the PHT-404 to be used in medium sized venues. The horn is made of a rigid die cast aluminium and the critical compression driver components are all controlled by P Audio's advanced quality and manufacturing systems.



## Specifications

Diaphragm Diameter	1.0 inch (25.4mm)
Nominal Impedance	8 Ohm
Voice Coil DC Resistance	7.2 Ohm
Power Handling	20 Watt
Sound Pressure Level (1W@1M)	105 dB
Magnet	Ferrite
Diaphragm Material	Phenolic Resin
Horn Material	Cast Aluminium
Nominal Coverage Angle (H x V) -6 dB	100° x 60°
Cutoff frequency	3 kHz
Baffle cutout dimension	85mm x 240mm 3.35" x 9.45"
Net Weight	1.1kg (2.42 lbs)
Shipping Weight	1.3kg (2.86 lbs)

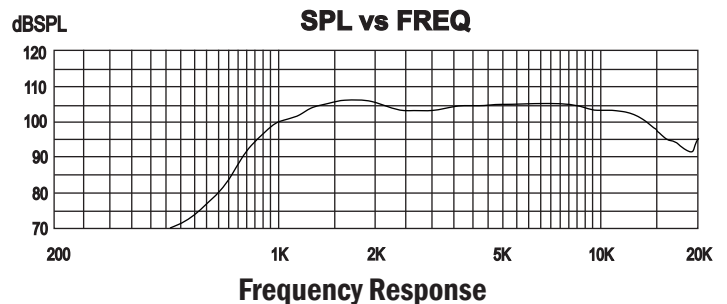
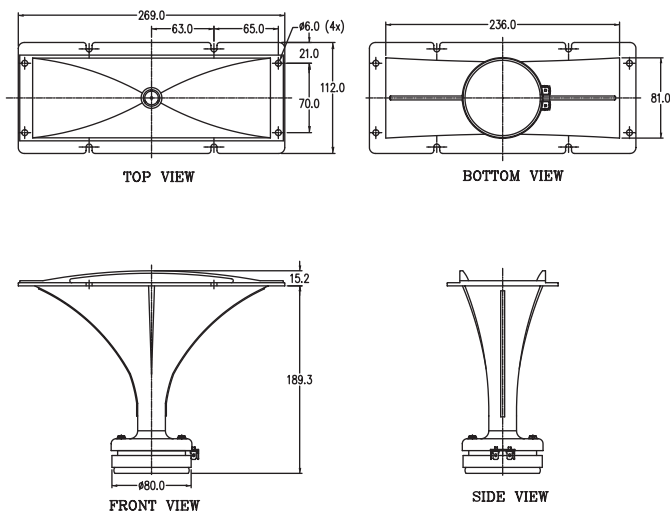

19/4 Moo 2 T.Bangkratuk A. Samparn Nakornpathom 73210 Thailand  
 Tel: +66-2-441-6600 Auto 30 Lines  
 e-mail: info@paudiothailand.com  
 Web site: www.paudiothailand.com  
 All rights reserved by P.Audio System Co., Ltd. 2007

