

ND1460A

Neo High Frequency Driver

Key Features

- 110 dB 1W/1m average sensitivity
- 1,4 inch exit throat
- 3 inch edgewound aluminum voice coil
- 160W program power handling
- Aluminum PEN diaphragm
- High grade neodymium magnetic structure
- Excellent thermal exchange



General Description

The ND1460A 1.4 inch exit neodymium HF compression driver has been designed for high level sound systems application.

The diaphragm assembly is composed by an aluminum dome sandwiched to a proprietary treated polyester suspension. This design maintains low resonance and lowers the minimum crossover point value at 800Hz. The composite diaphragm assembly is made by an aluminum dome strongly joined to the PEN suspension, in order to assure unmatched transient response. The lower density of the aluminum and PEN structure permits higher levels of sensitivity, especially in the mid-high frequency range.

A bended former edge-wound aluminum 75mm voice coil completes the diaphragm assembly. The proprietary treated Nomex former material shows 30% higher value of tensile elongation at working operative temperature (200°C) when compared to Kapton. Moreover, Nomex is suitable to work also in higher moisture contents environments. The bended former is jointed in a sandwich configuration between PEN suspension and the aluminum dome, assuring extended frequency energy transfer for improved response linearity and unparallel reliability.

Through careful use of elementary pieces of neodymium magnets, Eighteen Sound engineers have developed a powerful neodymium magnet assembly able to reach 19 KGauss in the gap in a compact and lightweight structure. The motor structure, throughout the precisely coherent phase plug with 3 circumferential slots and copper ring on the pole piece, reduces inductance effects and distortion. Four top plate air ducts were designed to act as a loading chamber for the diaphragm, implementing mid band distortion and response figures.

The custom designed O-ring creates a tight seal between the plate and the cover assuring air chamber loading. Excellent heat dissipation and thermal exchange are guaranteed by the direct contact between the magnetic structure and the aluminum cover that allows to obtain a lower power compression value.

The ability to perform properly under inclement weather conditions is a key-point of Eighteen Sound philosophy. The special coating applied to the magnet and the top and back plates of the magnetic structure makes the ND1460A compression driver resistant to the corrosive effects of salts and oxidization.

0422A8M600 8ohm
0422A6M600 16ohm

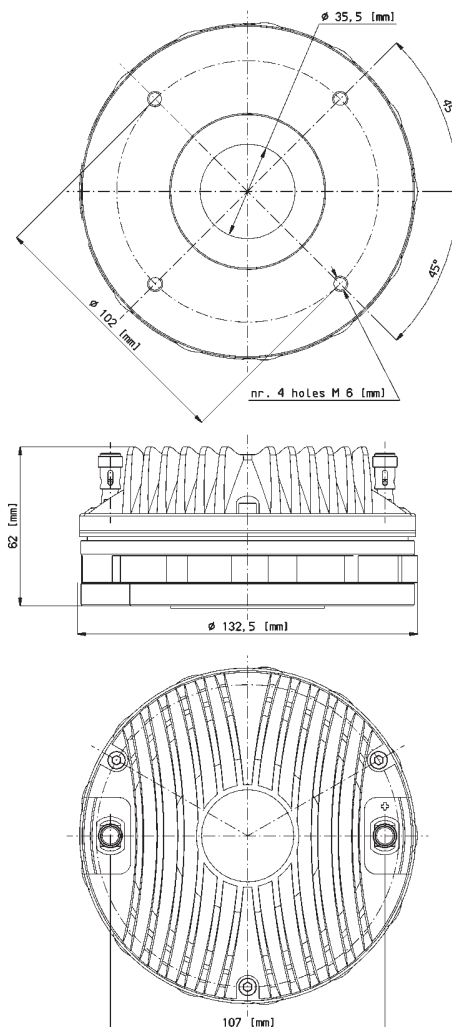

NEODYMIUM HF DRIVERS

ND1460A

Neo High Frequency Driver

GENERAL SPECIFICATIONS

THROAT DIAMETER	35,5 mm (1,4 in)
RATED IMPEDANCE	8 ohm
DC RESISTANCE	6,2 ohm
MINIMUM IMPEDANCE	8 ohm at 3500 Hz
LE (AT 1KHZ)	124 µH
AES POWER (1)	80 W above 1,2 kHz
PROGRAM POWER (2)	160 W above 1,2 kHz
SENSITIVITY(1W@1M) (3)	110 dB
FREQUENCY RANGE	500 Hz ÷ 20 kHz
RECOMM. XOVER FREQUENCY	above 800 Hz (12 dB/octave)
DIAPHRAGM MATERIAL	Aluminum - Polyethylene
VOICE COIL DIAMETER	75 mm (3 in)
VOICE COIL WINDING MATERIAL	Edge-wound aluminum
MAGNET MATERIAL	Neodymium
FLUX DENSITY	1,9 T
BL FACTOR	13,5 N/A
POLARITY	Positive voltage on red terminal gives positive pressure in the throat

MOUNTING INFORMATION

Overall diameter	132,5 mm (5,22 in)
Mounting holes diameter	4 M6 holes 90° at Ø102 mm (4 in)
Bolt circle diameter	102mm (4 in)
Total depth	62 mm (2,5 in)
Net weight	3,2 Kg (7,1 lb)
Shipping weight	3,4 Kg (7,5 lb)
CardBoard Packaging dimensions	132x132x68 mm (5,2x5,2x2,7 in)

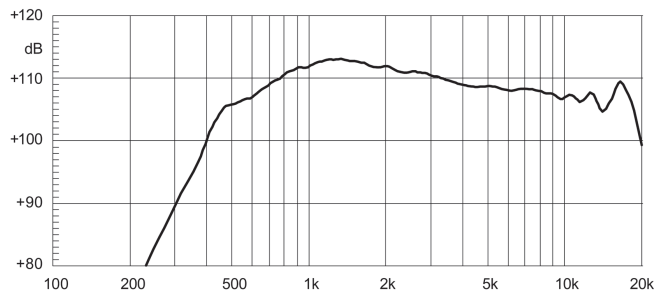
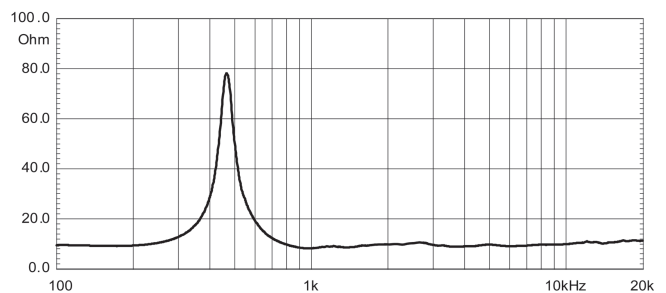
ND1460A MEASURED WITH 1W INPUT ON RATED IMPEDANCE AT 1 M DISTANCE ON AXIS FROM THE MOUTH OF XT1464 HORN**FREE AIR IMPEDANCE MAGNITUDE CURVE****NOTES**

- (1) AES power rating is tested with a pink noise input having a 6 dB crest factor for two hours duration within the specified range. Power calculated on minimum impedance.
- (2) Program power rating is defined as 3 dB greater than AES rating, and is a conservative expression of the transducer ability to handle music program material.
- (3) Sensitivity is measured at 1W input on rated impedance at 1m on axis from the mouth of XT1464 horn, averaged between 1kHz and 4 kHz.

Eighteen Sound engages in research and product improvement. New materials and design refinements can be introduced into existing products without notice.